

STAGE 1 - PRELIMINARY SITE PLAN  
**NCRSP - PARCEL 49**  
**HOMEWOOD SUITES HOTEL**  
 LOT 9 - PARCEL 1  
 MAJOR PROJECT PERMIT  
 ROSEVILLE, CA

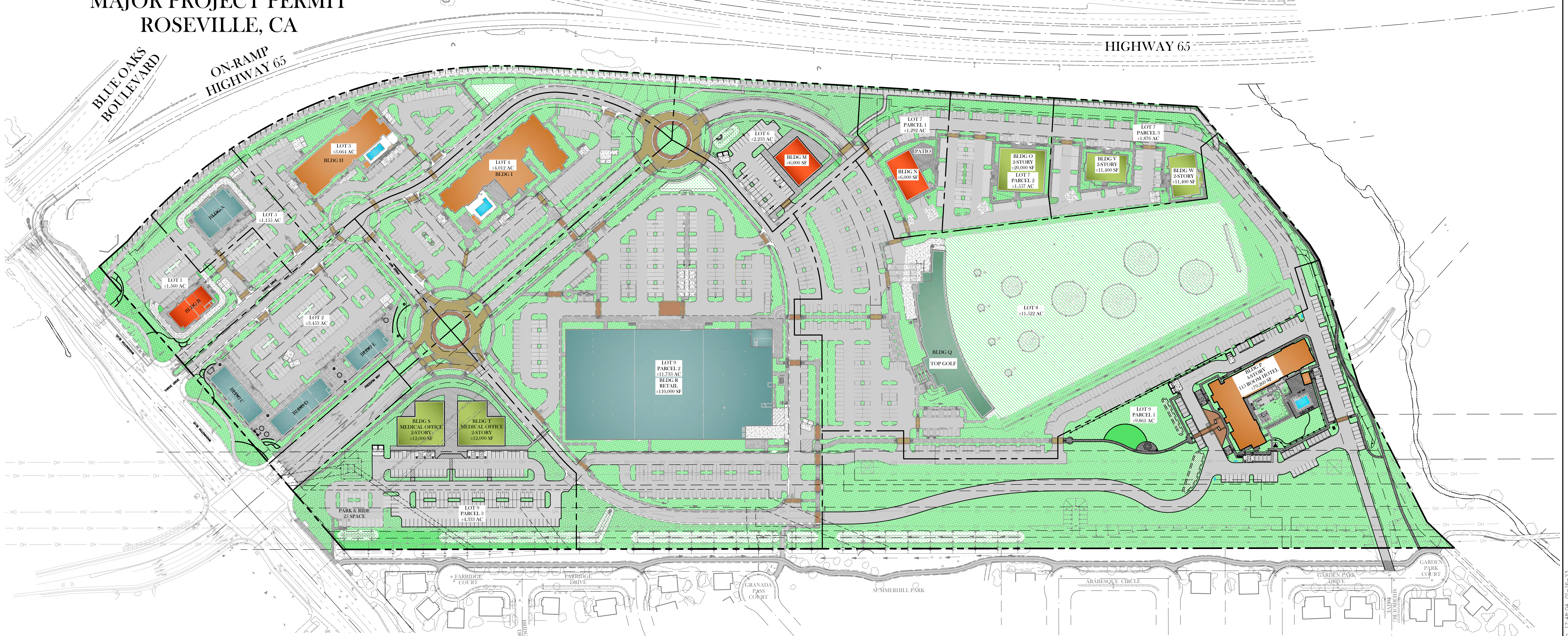

**PARCEL 49 PARKING SUMMARY**

Space	Use	Stories	Approx. SQ. FT.	Parking Ratio	Required	Provided
A	Restaurant/Fast Food	1	2,290	1/500	46	46
A	Retail	1	2,500	1/300	8	8
A	Retail	1	2,100	1/300	7	7
B	Restaurant/Fast Food	1	2,500	1/500	50	50
B	Retail	1	2,500	1/300	8	8
C	Restaurant	1	2,000	1/100	20	20
C	Retail	1	4,000	1/300	13	13
D	Restaurant	1	3,375	1/300	34	34
D	Retail	1	3,375	1/300	11	11
E	Restaurant	1	2,500	1/100	25	25
E	Retail	1	2,000	1/300	7	7
					229	261
H	Hotel (107 rooms)	4	63,692	1 per room	107	104
I	Hotel (104 rooms)	4	77,975	1 per room	104	110
M	Restaurant	1	6,000	1/100	60	53
N	Restaurant	1	4,000	1/100	40	80
O	Office	2	20,000	1/250 (non-hq. sq)	72	72
V	Office	2	11,400	1/250 (non-hq. sq)	41	41
W	Office	2	11,400	1/250 (non-hq. sq)	41	41
					214	239
P	Hotel (115 rooms)	4	79,260	1 per room	115	118
Q	Outdoor Recreation (Top Golf)	3	64,232		439	421
R	Retail	1	108,500	1/300	362	362
R	Restaurant	1	1,500	1/100	15	15
					377	377
S	Medical Office	2	12,000	1/100	80	80
T	Medical Office	2	12,000	1/100	80	80
					160	160
	Additional Parking Spaces (Park & Ride)					27
<b>SITE TOTALS:</b>					<b>502,949</b>	<b>1805</b>

**NCRSP - PARCEL 49 FLOOR AREA SUMMARY**

Space	Use	Stories	Approximate SQ. FT.	
A	Restaurant/Fast Food	1	2,290	
B	Restaurant/Fast Food	1	2,500	
C	Restaurant	1	2,000	
D	Restaurant	1	3,375	
E	Restaurant	1	2,500	
M	Restaurant	1	6,000	
N	Restaurant	1	4,000	
R	Restaurant	1	1,500	
<b>RESTAURANT TOTAL:</b>				
<b>26,165</b>				
O	Office	2	20,000	
V	Office	2	11,400	
W	Office	2	11,400	
<b>OFFICE TOTAL:</b>				
<b>42,800</b>				
S	Medical Office	2	12,000	
T	Medical Office	2	12,000	
<b>MEDICAL OFFICE TOTAL:</b>				
<b>24,000</b>				
A	Retail	1	4,450	
B	Retail	1	2,500	
C	Retail	1	4,000	
D	Retail	1	3,375	
E	Retail	1	2,000	
R	Retail	1	108,500	
<b>RETAIL TOTAL:</b>				
<b>124,825</b>				
H	Hotel (107 rooms)	4	63,692	
I	Hotel (104 rooms)	4	77,975	
P	Hotel (115 rooms)	4	79,260	
<b>HOTEL TOTAL:</b>				
<b>220,927</b>				
Q	Outdoor Recreation (Top Golf)	3	64,232	
<b>RECREATION TOTAL:</b>				
<b>64,232</b>				
<b>SITE TOTALS:</b>				
<b>502,949</b>				

**PARCEL 49 PROJECT SUMMARY**

**OWNER**  
 BSO LLC  
 8205 SIERRA COLLEGE BLVD  
 ROSEVILLE, CA 95661  
 ATTN: JOHN STEWART  
 johns@bsosideonline.com

**DEVELOPER**  
 CORE HOTELS, LLC  
 212 SUTTER STREET  
 3RD FLOOR  
 SAN FRANCISCO, CA 94108  
 SHAILENDRA SAM DEVDHARA  
 samd@corehotelsllc.com  
 415-982-1416 EXT. 7051

**ENGINEER**  
 TSD ENGINEERING, INC.  
 785 ORCHARD DR #110  
 FOLSOM, CA 95630  
 ATTN: CASEY FEICKERT  
 cleickert@tsdeng.com  
 916-608-0707

**ASSESSORS PARCEL NO & LOT AREA**  
 TOTAL (GROSS) - +58,883 AC

LOT	APN	EXISTING	PROPOSED	ZONING	LAND USE
LOT 1	363-022-021	+1,560 AC		PD/SA-NC & MI/SA-NC	GENERAL PLAN DESIGNATION LI (LIGHT INDUSTRIAL)
LOT 2	363-022-020	+3,453 AC			NCRSP SPECIFIC PLAN LI (LIGHT INDUSTRIAL)
LOT 3	363-022-023	+3,664 AC			
LOT 4	363-022-024	+4,012 AC			
LOT 5	363-022-022	+1,155 AC			
LOT 6	363-022-018	+2,233 AC	+1,292 AC		
LOT 7 PARCEL 1	363-022-017	+4,725 AC	+1,537 AC		
LOT 7 PARCEL 2			+1,876 AC		
LOT 7 PARCEL 3					
LOT 8	363-022-016	+11,522 AC			
LOT 9 PARCEL 1	363-022-025	+9,861 AC			
LOT 9 PARCEL 2	363-022-026	+11,733 AC			
LOT 9 PARCEL 3	363-022-027	+4,333 AC			

**USE**  
 MIXED USE COMMERCIAL CENTER

**PUBLIC ROAD**  
 RIGHT-OF-WAY - +0.641

**NUMBER OF LOTS**  
 11 EXISTING LOTS  
 13 PROPOSED LOTS

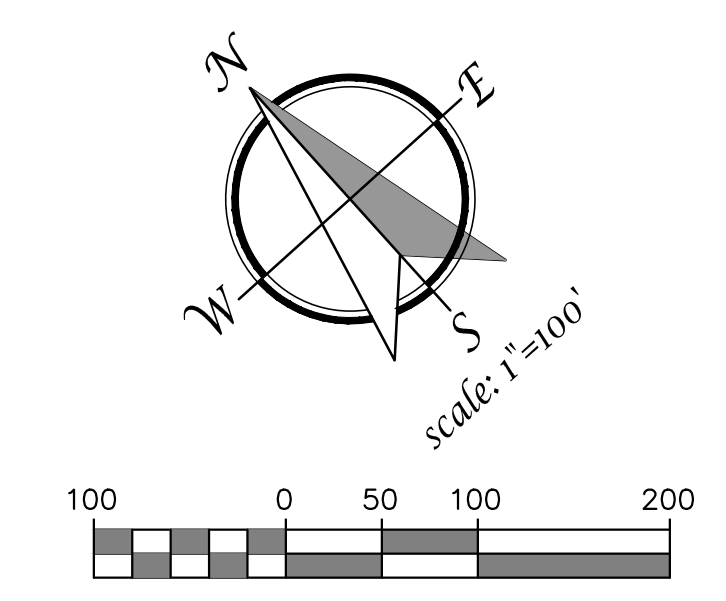

PRELIMINARY OVERALL SITE PLAN  
 JANUARY 13, 2023

**TSD ENGINEERING, INC.**  
 expect more.

785 Orchard Drive, Suite #110  
 Folsom, CA 95630  
 Phone: (916) 608-0707  
 Fax: (916) 608-0701



STAGE 1 - PRELIMINARY SITE PLAN - EAST  
**NCRSP - PARCEL 49**  
**HOMEWOOD SUITES HOTEL**  
 LOT 9 - PARCEL 1  
 MAJOR PROJECT PERMIT  
 ROSEVILLE, CA  
 SHEET 2 OF 2

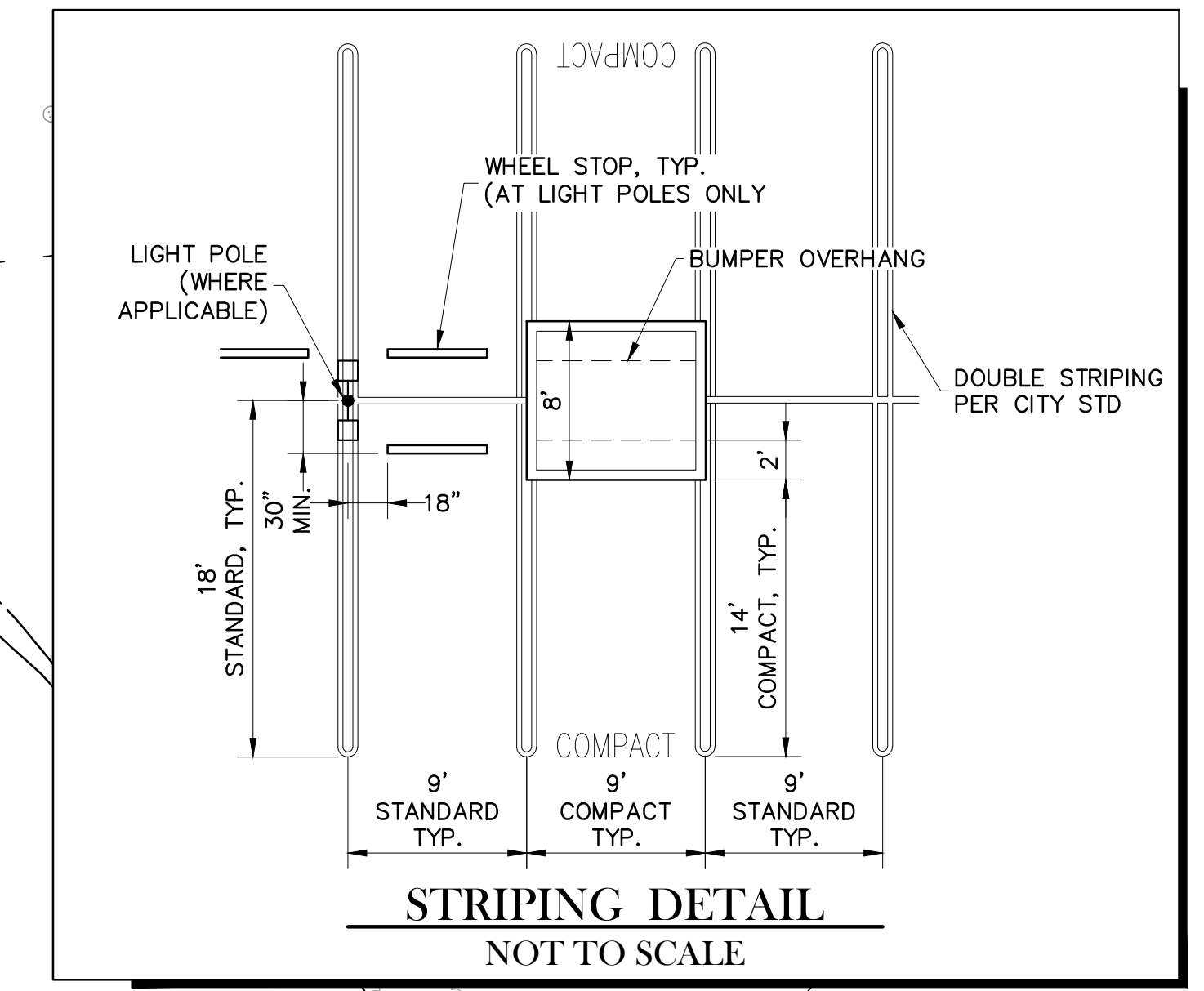
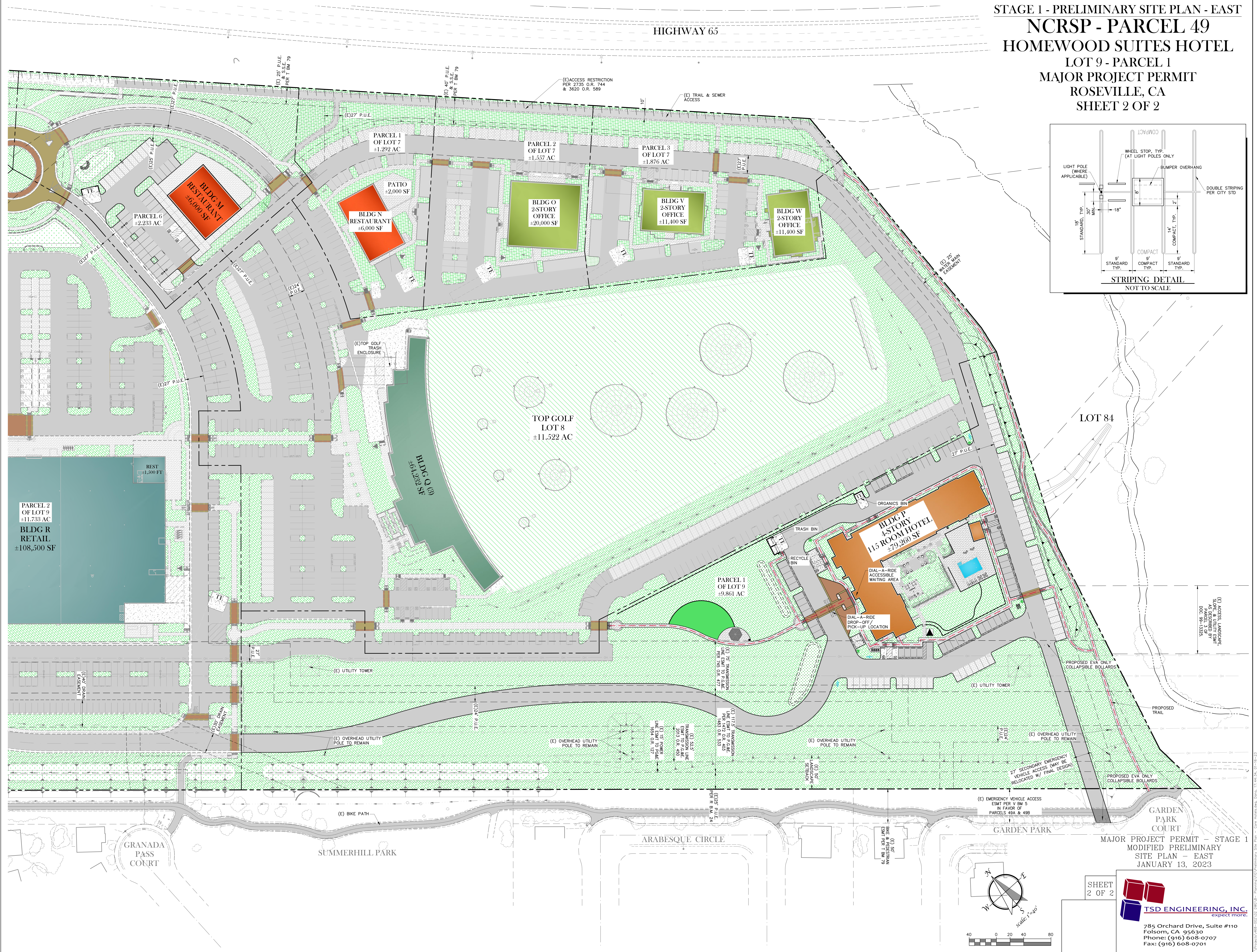

LOT 84

MAJOR PROJECT PERMIT - STAGE 1  
 MODIFIED PRELIMINARY  
 SITE PLAN - EAST  
 JANUARY 13, 2023

SHEET  
 2 OF 2

**TSD ENGINEERING, INC.**  
 expect more.  
 785 Orchard Drive, Suite #110  
 Folsom, CA 95630  
 Phone: (916) 608-0707  
 Fax: (916) 608-0701

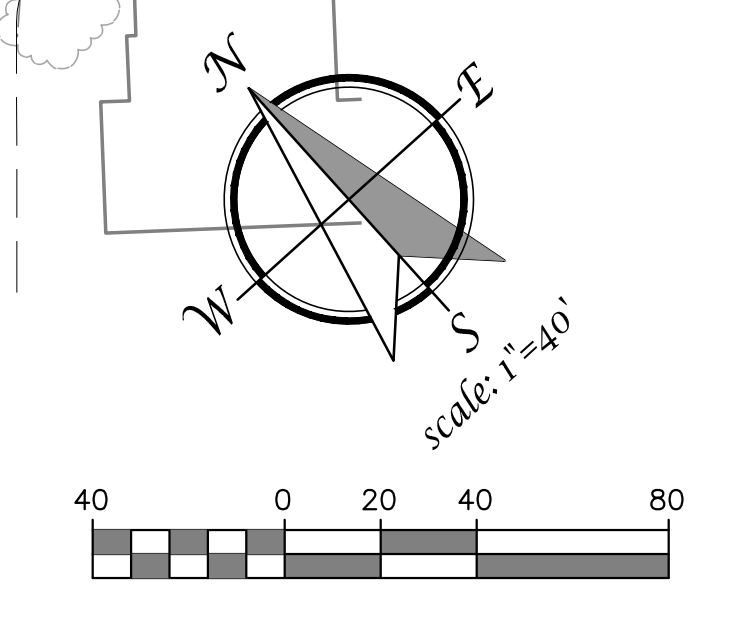

(E) ACCESS, LANDSCAPE,  
 SORE & UTILITY EASE-  
 AS PARCEL 1 OF  
 DOC. 98-1325

P:\Projects\488-002\02 DWG\10 - Preliminary\01 Preliminary Site Plan - Core\1088888.dwg, 1/14/23, 09:42:23

STAGE 1 - PRELIMINARY SITE PLAN  
**NCRSP - PARCEL 49**  
**HOMEWOOD SUITES HOTEL**  
 LOT 9 - PARCEL 1  
 MAJOR PROJECT PERMIT  
 ROSEVILLE, CA

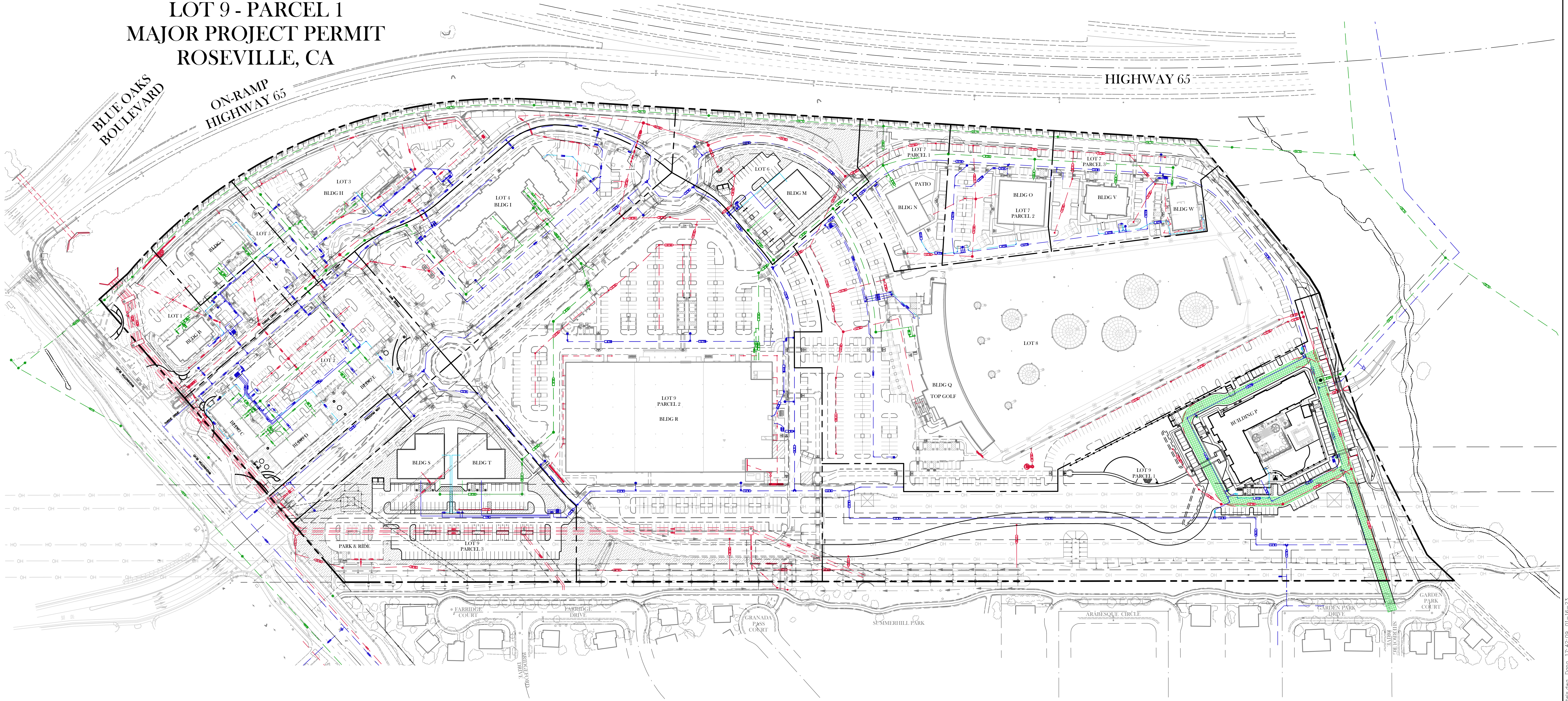

PRELIMINARY UTILITY PLAN  
 JANUARY 13, 2023

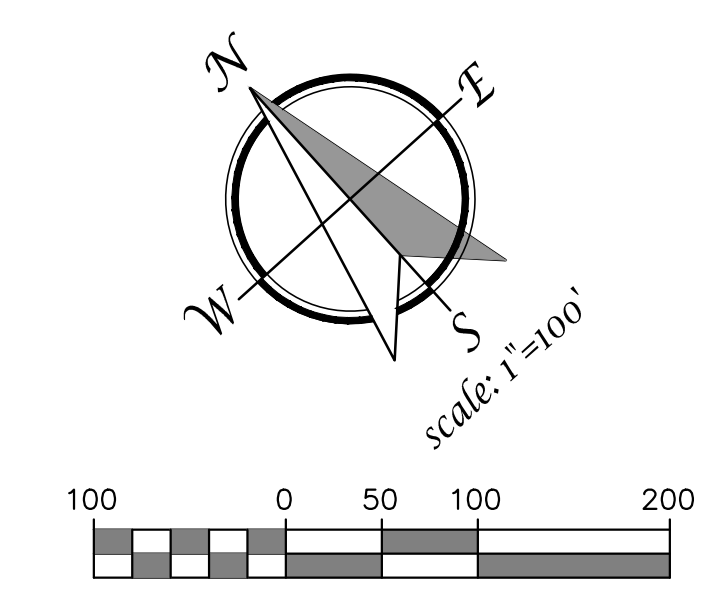

**TSD ENGINEERING, INC.**  
 expect more.  
 785 Orchard Drive, Suite #110  
 Folsom, CA 95630  
 Phone: (916) 608-0707  
 Fax: (916) 608-0701

P:\Projects\468-002\02 DWG\B- Planning\06\Preiminary Utility Plan - Core Hotels.dwg, Date: 17:42:09, 01-16-23